



\$79,893 USD

Tous les prix sont en devise U S et payable directement à Rottler MFG.

- Condition de vente : 10% avec la commande et 90% quand la machine est prête à être expédiée de chez Rottler.
- Le prix du transport sera proposé par Rottler au moment de l'expédition
- Certification CSA si le client le désire 1400\$ Canadien payable à C A G Équipement

F10XS

Rottler CNC Automatic Programmable Hole-to-Hole Cylinder Boring Machine 1.5 - 9.0" (38 - 230mm) Diameter with Optional Equipment

- CNC (Computer Numerical Control) Machine using Windows Operating System and Industrial PC with Intel Processor.
- Precision Programming and Control thru a 15" (367mm) Computerized Touch Screen.
- Software for Programmable & Automated Cycles such as Boring, Sleeving, Counterboring and Blind Hole Machining
- Chip shield & Dust Collector (504-35-11E)
- USB flash drive for file transfer to and from computer
- Internet connection to the machine computer must be provided for training support and service.
- Machine/Computer can operate in either inch or metric system
- Machine Work Head Floats on Air Cushion for Precision Centering - Total Travel - Left/Right Direction 44" 1117mm
- All motors - AC Servo Motors with BISS Encoders - Infinitely Variable
- Vertical Movement (Z Axis) - Up and Down – 15" (380mm)
- Horizontal Travel (X Axis) - Left and Right - 44" 1117mm
- Vertical and Spindle Load Monitoring for Fast Overload Shut Down
- Precision Position Display in .0001" (.002mm) Resolution.
- Electronic Hand Wheel for manual movement - per click: Coarse Mode .01" (.25mm) Medium Mode .001" (.01mm) Fine Mode .0001" (.002mm)
- Infinitely Variable Feedrates adjustable by hand wheel during automatic cycles
- High Performance Spindle Rotation AC Brushless Servo Motor - infinitely variable to 1200RPM
- Heavy Duty Hard Chromed Precision Spindle 3.25" (82.5mm) Diameter with High Speed Angular Contact Bearings supported with Adjustable Conical Outer Bearings
- Spindle with Quick Change Cutterhead System
- Fast Rapid and Jog Speeds for Reduced Cycle Time
- Automatic Work Head Tilt System for Back Clearance during Spindle Retract
- One Piece Heat Treated Mehanite Cast Iron Machine Castings
- Turcite Coated Slideways for Low Friction and Extended Life
- Automatic Central Lubrication System monitored by computer
- Operation, Programming and Spare Parts Manual - Digital
- Paint Color Code: RAL9002 (Grey White)
- Electrical requirements: 208-240V, 30A, 50/60Hz, 1Ph
- Shipping weight 3700lbs. (1,682 kg) without fixtures
- Shipping dimensions: 67 X 77 X 91" (1702 X 1956 X 2311mm)
- Prices (US Funds) - Freight Terms: EX WORKS, Kent, Washington, USA
- Please indicate on the order if factory tech or sales rep will perform installation.

OUTILLAGES OPTIONNEL

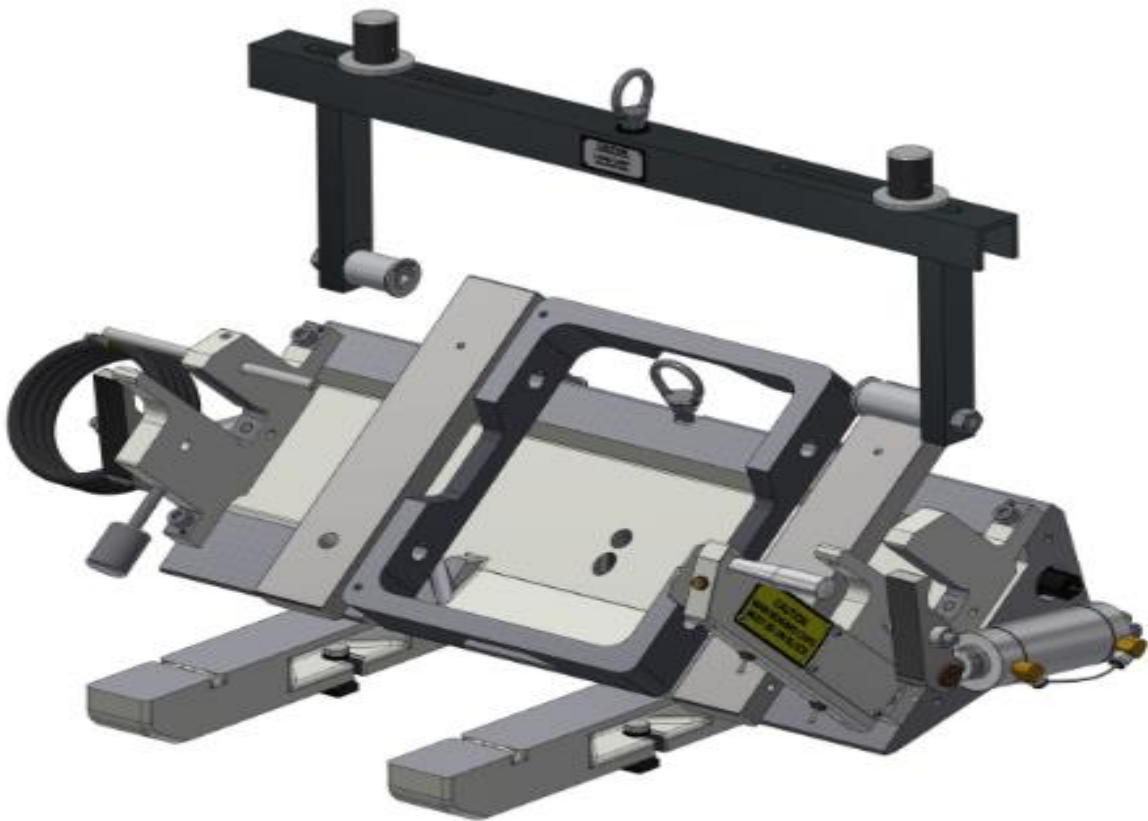

502-1-72F

V Block Fixture with Air Float and Air Clamping

\$8264

PARTS REQUIRED WITH 502-1-72F

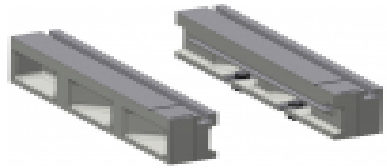

7219W

Universal
5.2"
(132.08mm)
Heavy Duty
T-Slot
Parallels



7330

Universal Economy Automotive Head and Block
Fixture

\$6107

PARTS REQUIRED WITH 7330



7219W

Universal
5.2"
(132.08mm)
Heavy Duty
T-Slot
Parallels



7242M

Clamp
Tower
Assembly (1
pair)



7331

Automotive and Diesel Fixture Assembly, Inline and Mid Range V-Fixture. Includes Adjustable Locators for Block Leveling as Well as Main Line Reference

\$4446

PARTS REQUIRED WITH 7331



11113L

Universal 4" (102mm) Heavy Duty T-Slot Parallels with Air Float, recommended for 11121 Upper Block Machining Fixture, 11113 Line Bore Fixture, 650-3-56 Line Bore Pivot Table.



7242M

Clamp Tower Assembly (1 pair)

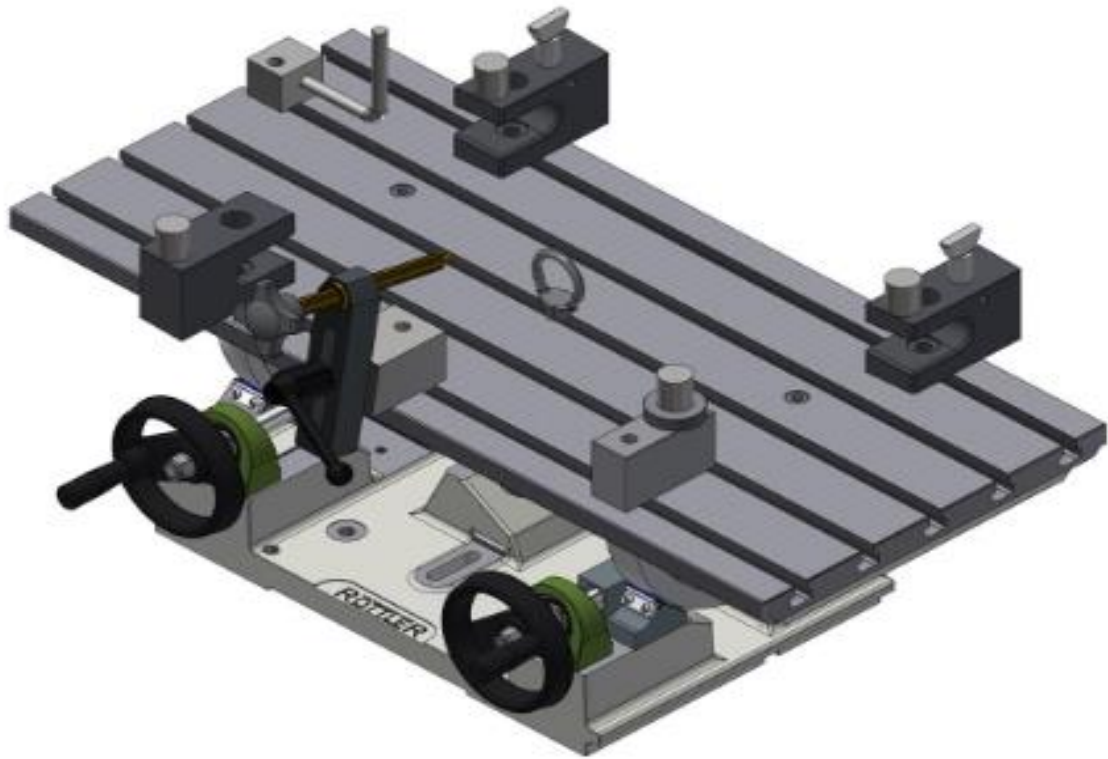

7209M

Universal Quick Action Dual Axis Leveling Table complete with universal work holding system for cylinder heads and small in-line blocks

Fits direct on the machine table between the head and tailstocks

\$8830

FREQUENTLY SOLD WITH 7209M



7219W Universal 5.2" (132.08mm) Heavy Duty T-Slot Parallels



7242M

Clamp Tower Assembly (1 pair)

\$2861



7219W

Universal 5.2" (132.08mm) Heavy Duty T-Slot
Parallels

\$1716

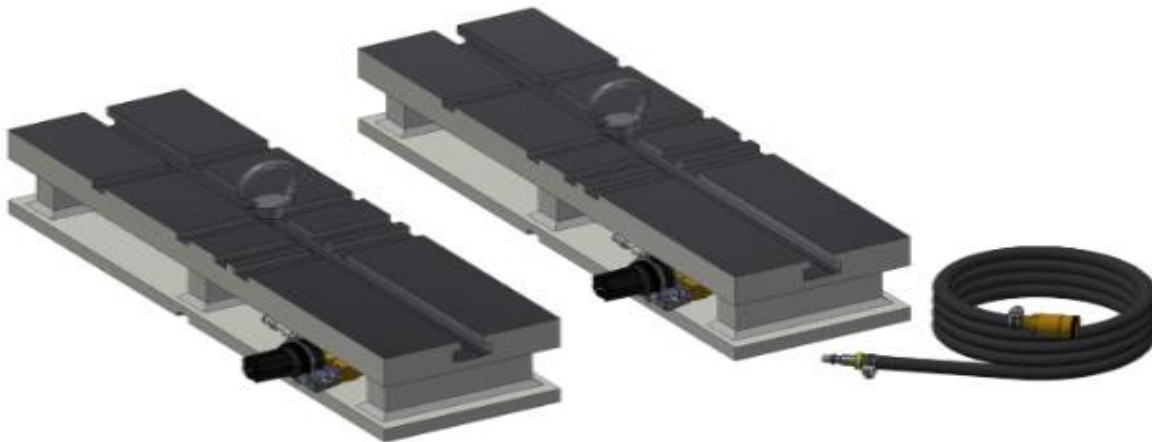

11113L

Universal 4" (102mm) Heavy Duty T-Slot Parallels
with Air Float, recommended for 11121 Upper
Block Machining Fixture, 11113 Line Bore Fixture,
650-3-56 Line Bore Pivot Table.

\$4650

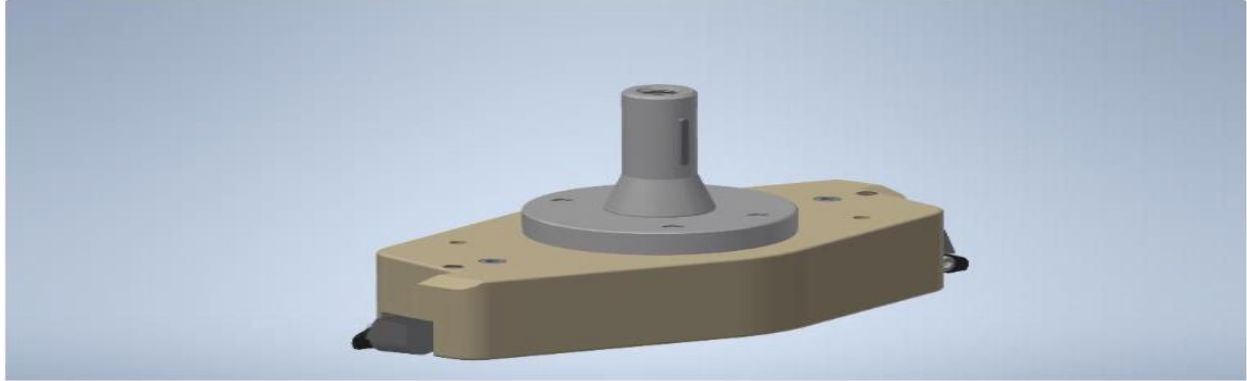

7206Z

Flycutter, 10" Assembly - F10XS

7206Z-10" to hit 15 R A or less Surface finish = \$2228

7206Z-14" to hit 15 – 20 R A Surface Finish \$2728



6303U

CBN Round Insert, Single Sided, 3/8" IC. For hard cast iron (15% Discount on orders of 10 or more)

\$336



6303M

PCD Round Insert, 3/8" IC, for super finishing aluminum (15% Discount on orders of 10 or more)

\$386

600-8-8A Blind Hole Stub Cutterhead, 1.5-4.1" Dia. X 3" Long

600-8-8B



501-72A



900-2-19

T8D



6801 Series

A

B

C

D

E

F



200-26-1



200-26-2

511-29-12D



RT321



RT322



RT211



RT212

\$4046

600-8-3A Blind Hole Stub Cutterhead, 1.5-4.1" Dia. X 5.25" Long



\$4046

600-2 Blind Hole Stub Cutterhead, 1.5-4.1" Dia. X 6.5" Long



\$4046

600-8-5 Blind Hole Cutterhead Kit, 2.6-5.0" Dia.

600-8-5A



900-2-19



200-21



200-21-3



501-72J

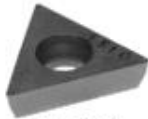

RT321



RT322



511-29-12D

F



G



H



J



K



L



6801 Series

\$5763

502-13M Stub Bar Cutterhead, 2.19-4.1" Dia. X 6" Long



\$5519

600-8-4L Cutterhead Kit, 2.875-5.0" Dia



RT321



RT322



RT212



RT211



511-29-12D



T8D



511-29-23 Series

\$4513

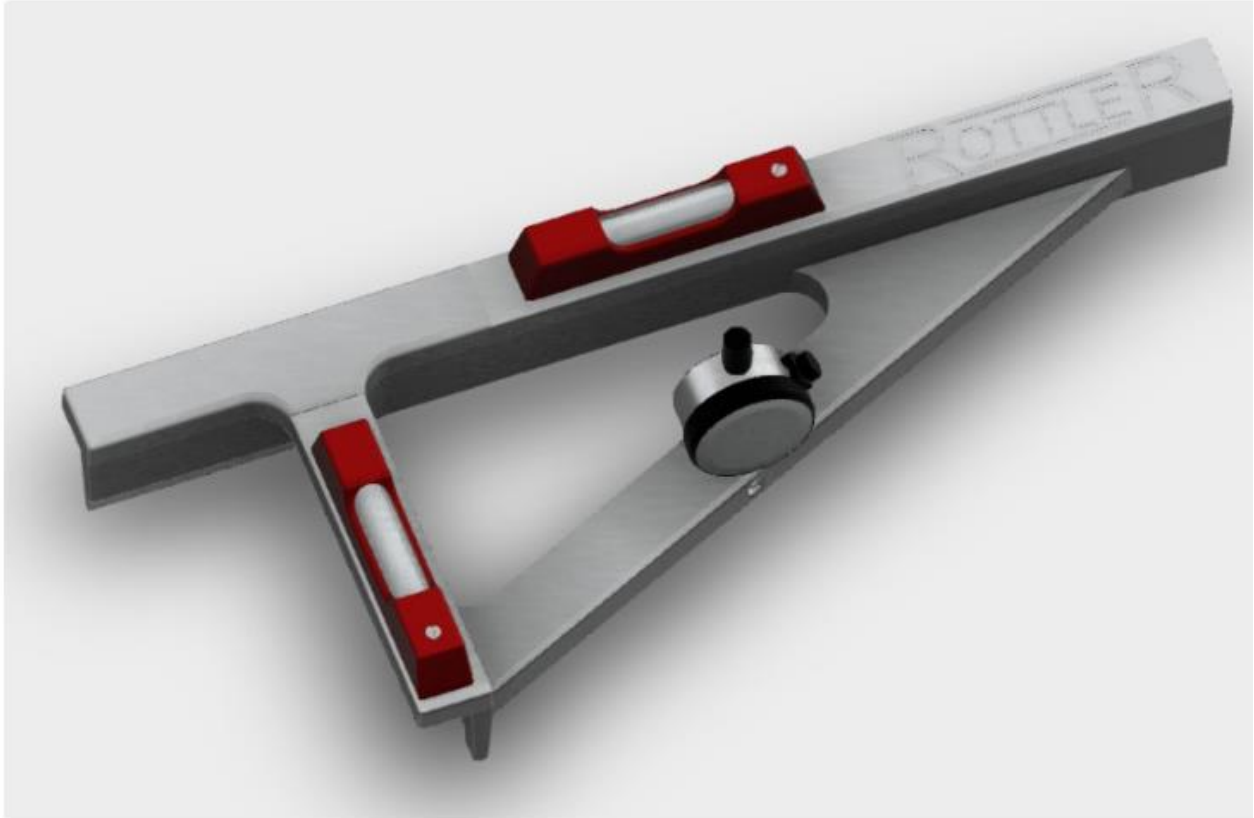

7152Q

Dual Axis Level Assembly

\$1084